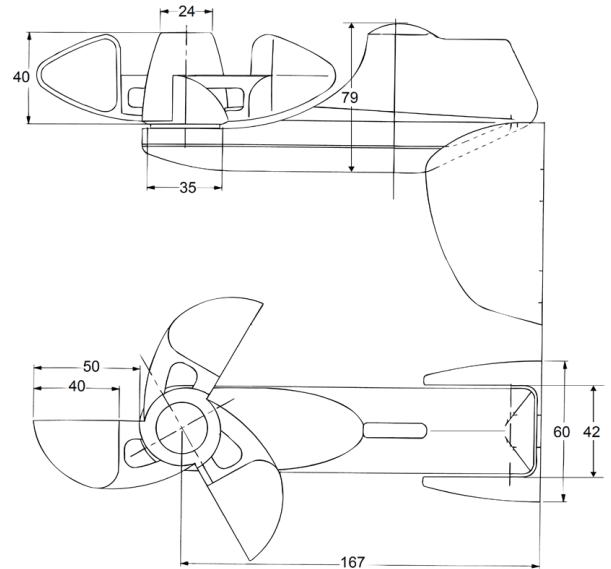

DOS**Distinctive
Outdoor Structures**

BE UNIQUE. BE DISTINCTIVE

SPECIFICATIONS:**EOLIS WIND SENSOR****TECHNICAL SPECIFICATIONS****CHARACTERISTICS**

Power	24 VDC
Material	ABS (UV proof)
Dimensions	9.29"L (236mm) x 2.36"W (60mm) x 6.3"H (160mm)
Frequency	50 - 60 Hz
Radiated Power	0dBm or 1mW
Modulation Type	ASK type A1
Wind Speed	12 - 62 mph
Protection Class	II
Range In Free Field	300 m
Operating Temperature Range	-22°F to 158°F (-30°C to +70°C)
Electrical Security	EN60730-1
Electromagnetic Compatibility	EN50081-1 EN50082-1
Radio	ETS 300 220
Shipping Weight	.51 lb. (230 g)
IP Rating	IP 34
Connectors	2 terminals (screws)
Plug	Organic 3-Prong Plug